

| LOC |    | DIST |         | REVISIONS         |         |    |      |
|-----|----|------|---------|-------------------|---------|----|------|
| AD  | 00 | P    | LTR     | DESCRIPTION       | DATE    | DN | APVD |
|     |    | P2   | REVISED | PER ECO-11-004587 | 11MAR11 | RK | HMR  |

- 1 OBSOLETE PART NO.
- 2 "AMP", PART NO. AND DATE CODE MARKED (WHITE), .062±.015 CHARS. WHEN HOUSING SIZE PERMITS
- 3 .046±.015 CHARS. MARKED (WHITE) FIRST AND EVERY 5TH CAVITY, ONE SIDE.
- 5 SUPERSEDED BY 3-87456-3.
- 6 SUPERSEDED BY 4-87456-5.
- 7 OBSOLETE PARTS: OBSOLETE CIS STREAMLINING PER D.RENAUD/D.SINISI

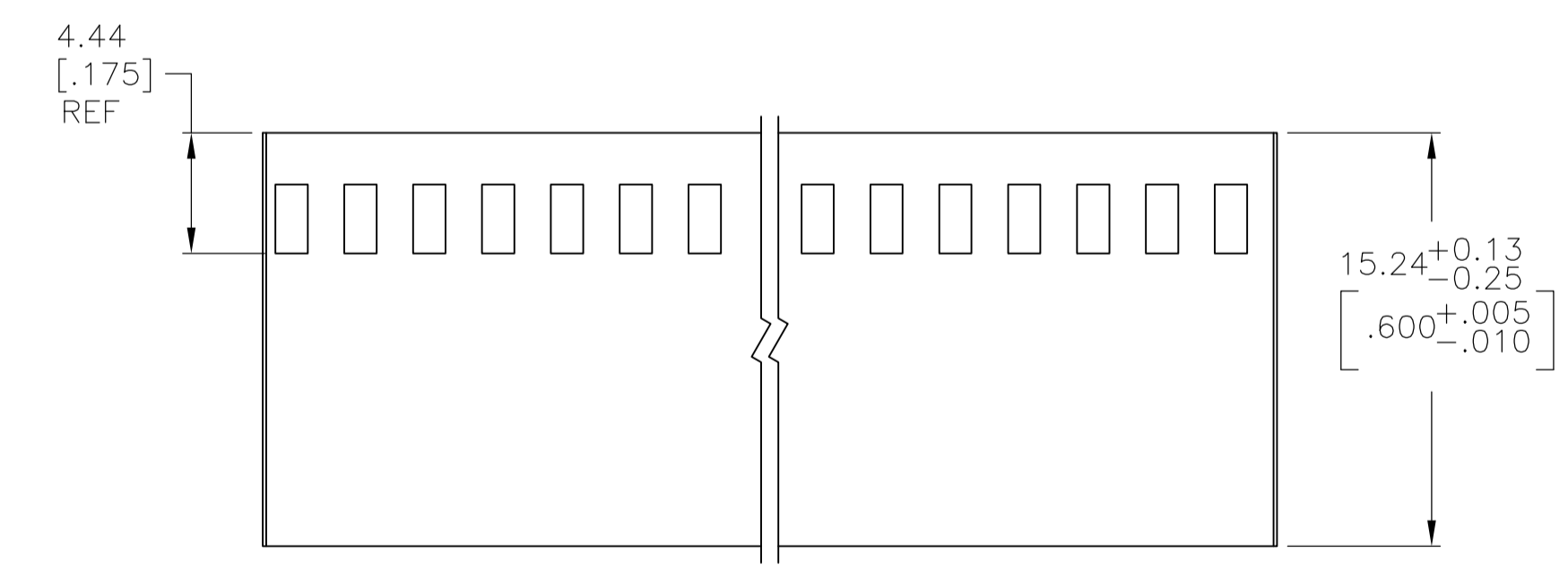
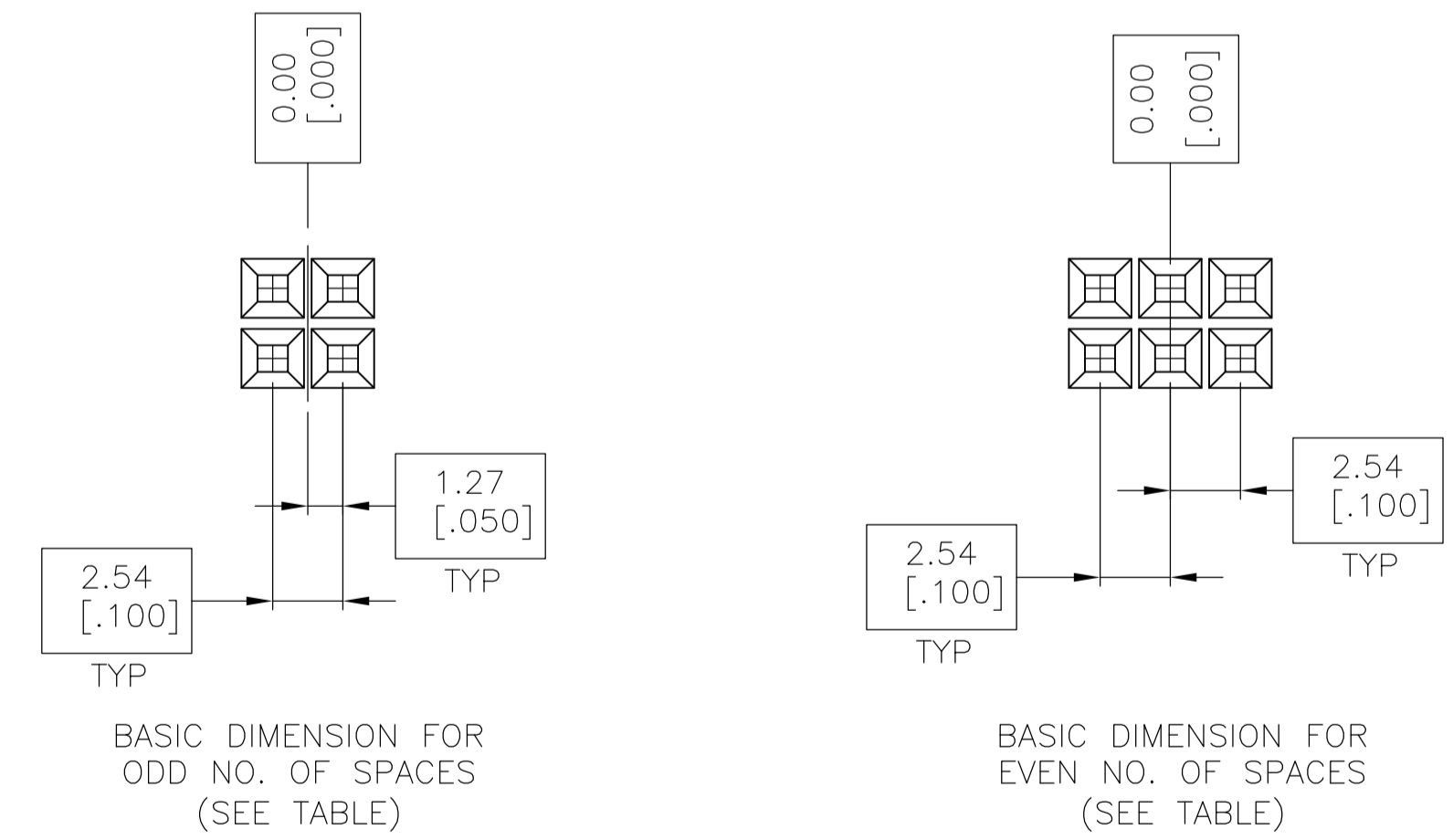
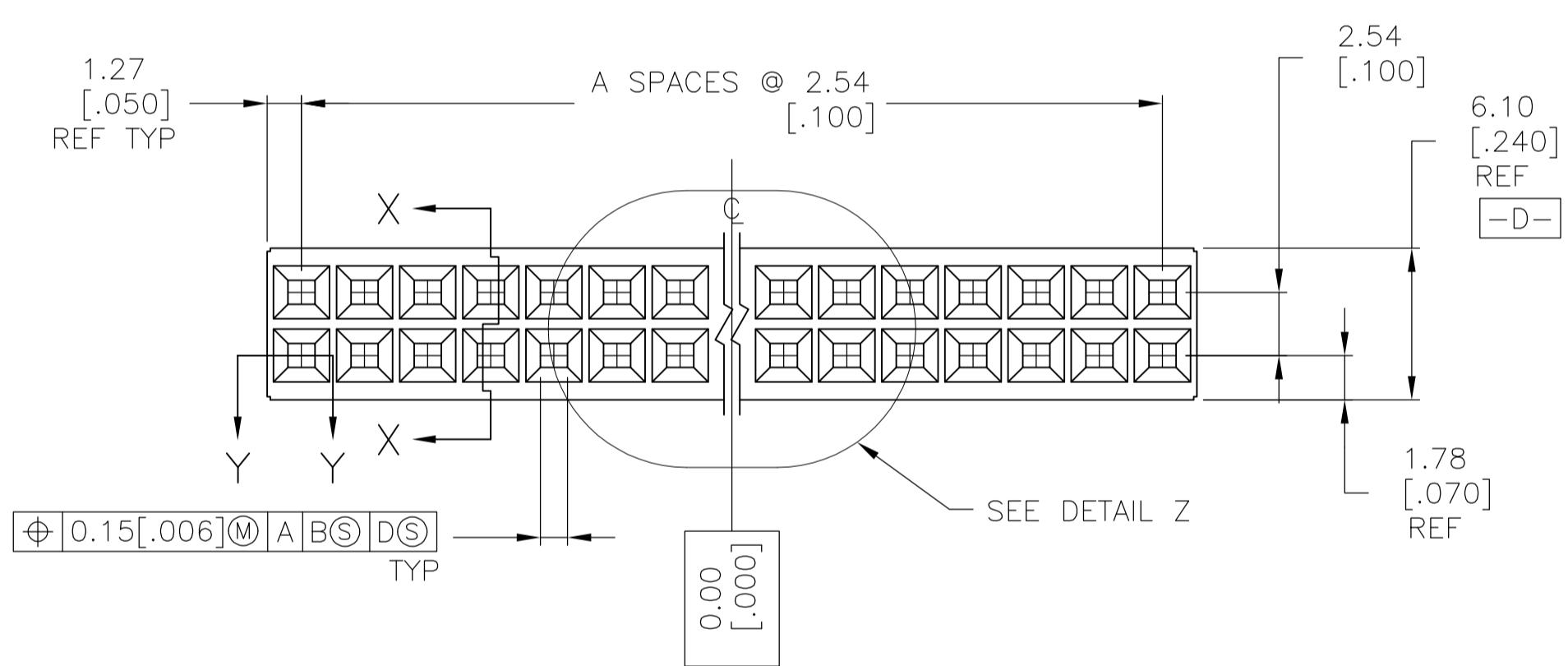
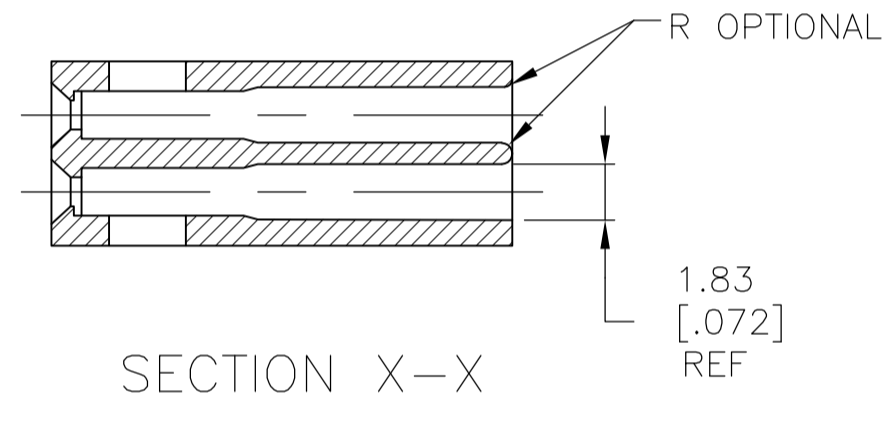
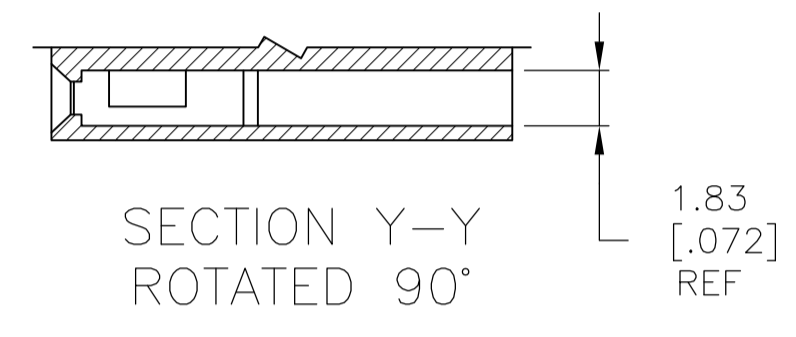
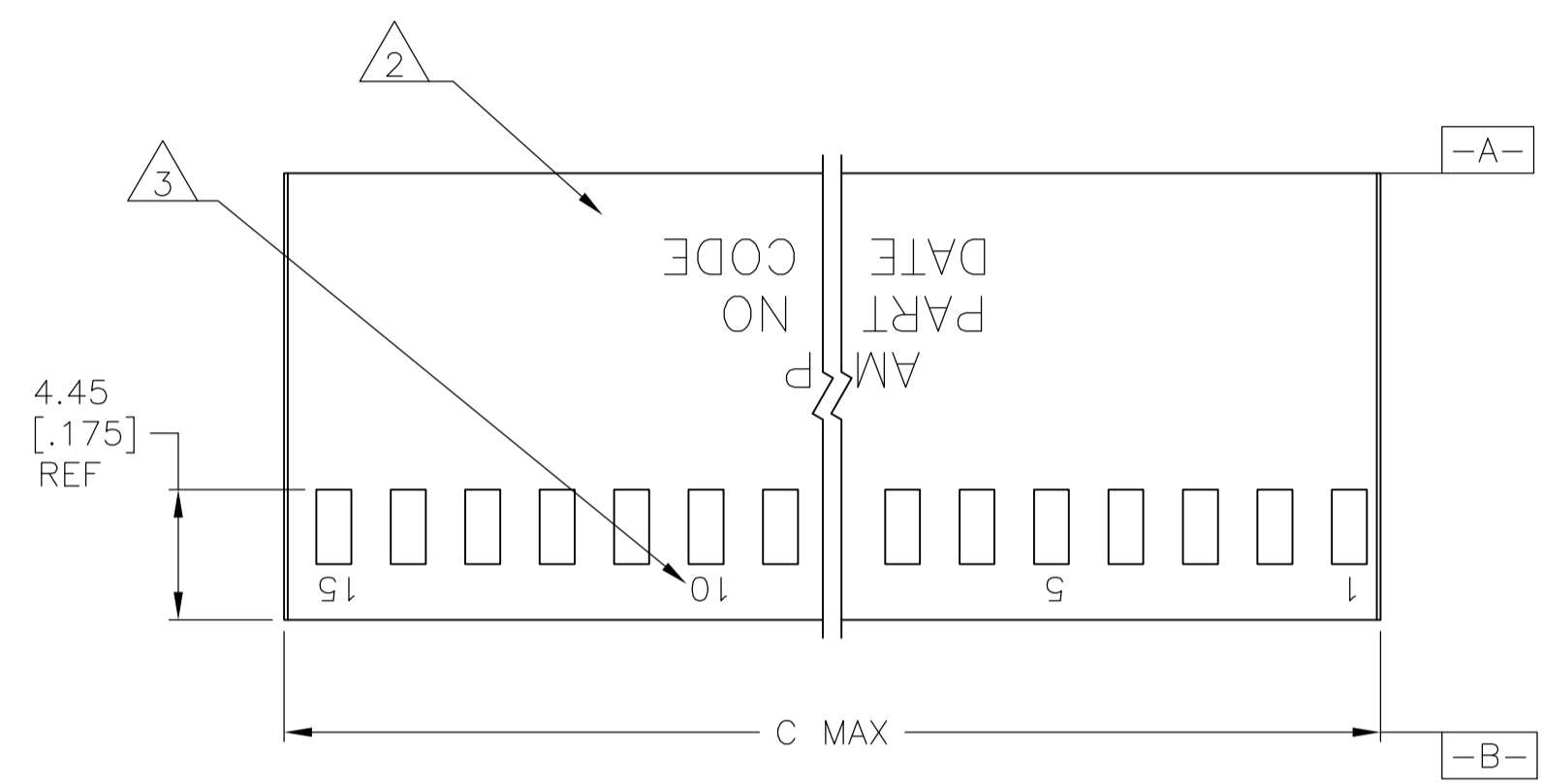

|                          |               |    |                  |                 |
|--------------------------|---------------|----|------------------|-----------------|
| 6-87456-5                | 81.28 [3.200] | 31 | 64               | 6-87456-6       |
| 6-87456-3                | 73.66 [2.900] | 28 | 58               | 6-87456-4       |
| 6-87456-1                | 71.12 [2.800] | 27 | 56               | 6-87456-2       |
| 5-87456-9                | 60.96 [2.400] | 23 | 48               | 6-87456-0       |
| 5-87456-7                | 83.82 [3.300] | 32 | 66               | 5-87456-4       |
| 5-87456-5                | 88.90 [3.505] | 34 | 70               | 5-87456-6       |
| 5-87456-3                | 2.67 [1.05]   | -  | 2                | -               |
| 5-87456-1                | 76.33 [3.005] | 29 | 60               | 5-87456-2       |
| 4-87456-9                | 5.21 [2.05]   | 1  | 4                | 5-87456-0       |
| 4-87456-7                | 91.57 [3.605] | 35 | 72               | 4-87456-8       |
| 4-87456-5                | 68.71 [2.705] | 26 | 54               | 4-87456-6       |
| 4-87456-3                | 53.47 [2.105] | 20 | 42               | 4-87456-4       |
| 4-87456-1                | 66.17 [2.605] | 25 | 52               | 4-87456-2       |
| 3-87456-9                | 63.63 [2.505] | 24 | 50               | 4-87456-0       |
| 3-87456-7                | 56.01 [2.205] | 21 | 44               | 3-87456-8       |
| 3-87456-5                | 50.93 [2.005] | 19 | 40               | 3-87456-6       |
| 3-87456-3                | 48.39 [1.905] | 18 | 38               | 3-87456-4       |
| 3-87456-1                | 45.85 [1.805] | 17 | 36               | 3-87456-2       |
| 2-87456-9                | 43.31 [1.705] | 16 | 34               | 3-87456-0       |
| 2-87456-7                | 40.77 [1.605] | 15 | 32               | 2-87456-8       |
| 2-87456-5                | 38.23 [1.505] | 14 | 30               | 2-87456-6       |
| 2-87456-3                | 35.69 [1.405] | 13 | 28               | 2-87456-4       |
| 2-87456-1                | 33.15 [1.305] | 12 | 26               | 2-87456-2       |
| 1-87456-9                | 30.61 [1.205] | 11 | 24               | 2-87456-0       |
| SUP BY 1-87456-7         | 28.07 [1.105] | 10 | 22               | 1-87456-8       |
| 1-87456-5                | 25.53 [1.005] | 9  | 20               | 1-87456-6       |
| 1-87456-3                | 22.99 [905]   | 8  | 18               | 1-87456-4       |
| 1-87456-1                | 20.45 [805]   | 7  | 16               | 1-87456-2       |
| 87456-9                  | 17.91 [705]   | 6  | 14               | 1-87456-0       |
| 87456-7                  | 15.37 [605]   | 5  | 12               | 87456-8         |
| 87456-5                  | 12.83 [505]   | 4  | 10               | 87456-6         |
| 87456-3                  | 10.29 [405]   | 3  | 8                | 87456-4         |
| 87456-1                  | 7.75 [305]    | 2  | 6                | 87456-2         |
| PART NO. WITHOUT MARKING | C             | A  | NO. OF POSITIONS | PART NO. MARKED |

THIS DRAWING IS A CONTROLLED DOCUMENT.

DIN E. BRANDBERG 11-06-92  
 CRK J. GESFORD 11-30-92

APVD J. GESFORD 11-30-92

NAME HOUSING, MOD IV  
 DOUBLE ROW, .100X.100 C/L  
 CRIMP SNAP-IN, SHORT ENTRY

PRODUCT SPEC

APPLICATION SPEC

SIZE A1 CAGE CODE DRAWING NO. 00779C=87456

RESTRICTED TO

MATERIAL GLASS FILLED NYLON  
 COLOR BLACK PER ASTM D4066

FINISH

WEIGHT

CUSTOMER DRAWING

SCALE 4:1 SHEET 1 OF 1 REV P2